

Electric Service Guide

Electric service requirement
reference guide for building
construction



Helping you receive the
best product, at the
best price, with the
best service.



**Singing River Electric
Power Association**

A Time Electric Energy Cooperative



Seven Cooperative Principles



As an electric cooperative we adhere to these cooperative principles.

1. Voluntary and Open Membership -

Cooperatives are voluntary organizations, open to all persons able to use their services.

2. Democratic Member Control -

Cooperatives are democratic organizations, owned by those we serve. We are controlled by our members, who actively participate in setting policies and making decisions. Customers serve as board of directors and are accountable to the membership.

3. Members' Economic Participation -

Members contribute equally to, and democratically control, the capital of their cooperative.

4. Autonomy and Independence -

Cooperatives are autonomous, self-help organizations controlled by their members. If they enter into agreements with other organizations, including governments, or raise capital from external sources, they do so on terms that ensure democratic control by members.

5. Education, Training and Information -

Cooperatives provide education and training for their members, elected representatives, managers and employees so they can contribute to the development of their cooperative.

6. Cooperation Among Cooperatives -

Cooperatives serve members most effectively and strengthen the cooperative movement by working together through local, national, regional and international structures.

7. Concern for Community -

While focusing on member needs, cooperatives work for the sustainable development of their communities through policies accepted by their members.

Welcome



**Singing River Electric
Power Association**

A Tachewas Energy Cooperative



Dear cooperative member:

Welcome to Singing River Electric Power Association! As a member, you join more than 63,000 customers who form our "member-owned" organization.

This member guide is designed as a reference for contractors, electricians, and individuals installing, repairing, or constructing a residential or commercial building that will receive electric service from Singing River Electric Power Association. We suggest you keep this information in a convenient place and refer to it when questions arise.

Again, welcome to Singing River Electric Power Association. We're pleased to have you join us, not only as a member, but also as a neighbor and friend.

Sincerely,

Lee Hedegaard
General Manager - CEO



Cooperatives are different from other forms of business because our first priority is you, our member owners. Focusing on providing you with the best product, at the best price, with the best service insures you have reliable electric service.

Introduction



Purpose

This booklet is designed as a reference for contractors, electricians, and individuals installing, repairing, or constructing a residential or commercial building that will receive electric service from Singing River Electric Power Association.

General

The information in this booklet is general and does not include every detail or lawful requirement. The booklet is designed only to assist you in planning.

All facilities constructed must be in compliance with the National Electrical Code, National Electric Safety Code and any applicable state and local laws and ordinances in the area. All work must be completed in a neat and orderly manner in accordance with accepted wiring practices before electric service connections are made.

Singing River Electric wants to serve its members promptly and satisfactorily. We will cooperate with contractors, electricians, and our members to the fullest extent possible in order to provide service in a timely and efficient manner.

Scope

This booklet refers primarily to the service entrance requirements at secondary voltages for residential and commercial installations. Single phase, 120/240 volt is the normal secondary voltage for residential and small commercial installations. Consumers with commercial installations requiring higher voltages or with service entrances greater than 200 amps should contact the Engineering Department at Singing River Electric.

Information



1. Applications for Service

Application for service can be made by calling any Singing River Electric office. A listing of the offices is located at the end of this booklet. The application for service must be completed in the name of the member or prospective member who is to be responsible for the account. A membership fee and connection charge will be required, and a security deposit may be required dependent upon the applicant's credit history. The member or prospective member must contact the proper city/county office (see pg. 5) if a permit, inspection, or registration is required. Service cannot be connected until Singing River Electric receives the proper permit, inspection or registration. When applicable, charges for service will be determined by Singing River Electric's Engineering Department. Members with mobile homes are required to present their Mobile Home Registration Certificate when applying for service.

In the event of changes in plans, location, or delivery points, the member must notify the Association promptly in order to receive approval. Also, suitable locations for the poles, transformers, meters, and other appurtenances of the Association necessary to supply service must be provided by the consumer, at no expense to the Association.

2. Interruption and Liability

The Association will endeavor to furnish continuous service but does not guarantee uninterrupted service and is not liable for any damage which may result from the failure or partial failure of the power, failure or reversal of phases, variation in service characteristics whether caused by accidents, repairs, storms, or other natural causes. Where three-phase service is required by the member, the installation and maintenance of adequate relays with circuit breakers to protect against single-phase conditions are the responsibility of the member.

Information



3. Service Entrance and Meter Locations

It is essential that the customer, electrician, or contractor contact Singing River Electric to determine what point on the building the Association's service drop wires will be attached. The customer must coordinate the point of service and location of metering equipment with Singing River Electric. Should the customer's service entrance be improperly located, the member may be required to reimburse the Association for expenses resulting from improper location.

Meter sockets will be installed outdoors and may be placed only in locations that are easily accessible to authorized Singing River Electric employees for meter reading, maintenance, inspecting, and removal.

4. Final Connections

All final connections, permanent or temporary, between the Association's lines and the member's wiring will be made by the Association. Unauthorized connections are not permitted.

5. Number of Services

The Association will connect only one service to a building or other structure, except as permitted by the National Electrical Code.

6. Underground Service

When underground service (120/240 volts) is desired, it is necessary to first consult with the Association. Underground installations for new residential or commercial buildings are subject to nonrefundable aid to construction.

7. Meter Tampering Seal

Tampering with the meter, installing conductors carrying unmetered current, or breaking an Association's meter seal without permission is prohibited by law and will not be tolerated by the Association.

Information

8. Permits, Inspections and Registrations

All wiring shall conform to the National Electrical Code and to state, municipal, and county ordinance requirements.

When applicable, the applicant must provide the Association with the appropriate permits, inspections, and registrations required by law. (Note: Applicants should request an inspection, from the appropriate agency, at least two working days before service is needed. Also, separate inspections are required for both temporary and permanent services.)

LOCAL CODES

| | | | |
|-----------------------|--------------|----------------------------|--------------|
| City of D'Iberville | 228-392-7966 | Harrison County | 228-832-1622 |
| City of Gautier | 228-497-1878 | Jackson County Plan. Comm. | 228-769-3057 |
| City of Moss Point | 228-475-0300 | Perry County | 601-964-8370 |
| City of Ocean Springs | 228-875-6712 | Wayne County | 601-735-3481 |
| City of Pascagoula | 228-938-6620 | Mobile County | 251-574-3507 |
| George County | 601-947-7506 | Washington County | 251-690-8794 |
| Greene County | 601-394-4185 | | |

9. Safety

Unauthorized consumer equipment such as antennas, satellite dishes, basketball goals, security lights, etc. shall not be attached to utility poles. Contact Singing River Electric before doing any work with cranes, antennas or other objects that may come within 10 feet of an Association power line. (This is a Mississippi law.) Also, antennas should not be installed within falling distance of an existing power line. Buildings, antennas, or other structures shall not be constructed or installed within the minimum distances established by the National Electrical Safety Code or state and federal regulations. Report any unsafe conditions to the association.

Contact Mississippi One Call at 1-800-227-6477 or Alabama One Call at 1-800-292-8525 two days prior to any excavations or digging. (This is a Mississippi law.) Commence with digging only after your work site has been marked. For more information visit www.ms1call.org.

Service Entrance



Clearance

Proper ground clearance must be maintained. Ground clearance is the measurement from the bottom conductor to the final finished grade. The member shall provide a point of attachment that will allow the Association to maintain the following minimum clearances with its service drop:

1. In places not accessible to vehicular traffic - no less than 12 feet.
2. Over public streets, alleys, roads, and driveways subject to truck traffic - no less than 18 feet.
3. The point of attachment of service drop wires will be selected so the wires will not interfere with windows, doors, awnings, or other parts of the building and shall be kept 3 feet away from windows, doors, porches, or other readily accessible areas.

Service Entrance Conductors

1. All service entrance conductors shall be of sufficient size to conform to the rated capacity of service entrance equipment.
2. SE cable or single conductors in conduit may be used. In either case, cable or conduit straps must be used to support the service entrance conductors at no more than 24-inch intervals.
3. Each conductor must extend 18 inches beyond the service head.
4. Splices are not permitted in the service entrance conductors.
5. Flexible cord such as welding cable is not permitted.
6. The minimum allowable service entrance for a permanent dwelling or residence is 100-amp. Some local electric codes allow a 60-amp service for construction and pump meter poles. For 120/240 volt, 3-wire, single phase dwelling service entrances, the 2005 National Electric Code permits the following minimum conductor sizes to be utilized:

Service Entrance



| Conductor Types and Sizes | | |
|---|--------------------------------------|---------------------------|
| RH-RHH-RHTHHW-THW-THWN-THHN-XHHW-USE-SE-USE-2 | | |
| Copper | Aluminum and Copper-Clad Aluminum | Service Rating in Amps |
| #6 | #4 | 60 |
| #4 | #2 | 100 |
| 2/0 | 4/0 | 200 |
| 400kcmil | 600kcmil | 400 |

7. Grounded conductors or neutral may be one size smaller than the largest ungrounded conductor and clearly marked at the weatherhead.
8. For commercial application, refer to the National Electric Code and local electric code departments for minimum allowable conductors sizes and service entrance requirements.

Some local electrical codes do not permit the use of aluminum for residential or commercial service entrance conductors.

Mast

1. For a residential service entrance of 200 amps or less, the minimum size conduit for a mast should be 2 inch I.D., rigid galvanized conduit or pipe.
2. Mast couplings are only permitted below the roof-line and must be visible from the exterior of the structure.
3. The mast shall be sufficiently braced and blocked to support the service conductors and shall be located at a point on the building where the service will not cross the roof, except the overhanging eave.
4. The mast shall be attached to the structure with conduit straps located not more than two feet apart.

Service Entrance



Ground Wire

1. For service of 200-amps or less, the minimum size ground wire shall be #4 solid bare copper.
2. The service entrance ground conductor and the #4 ground wire must be grounded to the center lug to the meter base.
3. The ground wire shall be without splice and continuous from meter base to the ground rod.
4. The ground wire shall be accessible on the outside of the structure.
5. The ground wire must be securely fastened to the structure with appropriate staples, clamps, etc.

Grounding Electrode (Rod)

1. An approved solid 5/8-inch copper clad or galvanized rod is recommended. However, a 3/4 inch galvanized pipe may be substituted.
2. A minimum length of 8 feet is required.
3. Metal tubing such as EMT shall not be used for the grounding rod.
4. If a metallic water system is present, it may not be used in lieu of a grounding electrode but may be used in conjunction with it.

Connection Between Ground Wire and Grounding Electrode

1. The connection between the ground wire and electrode shall be easily accessible and shall not be covered by concrete or any other substance.
2. The ground clamp must be U.L. approved type for service entrance grounding.

Disconnect Devices Shall Conform to the NEC as follows:

1. The disconnecting means shall consist of not more than six switches, circuit breakers or fuses in a common enclosure or accessible group of separate enclosures. An accessible group is taken to mean that the discon-

Service Entrance



necting devices are to be located at one point with no intervening partitions or wall and can be readily reached from one point.

2. Means shall be provided to disconnect all conductors in a building or other structure from the service entrance conductors. It is recommended that the disconnecting devices be located adjacent to the meter base on the exterior of the building or structure. However, the National Electric Code does allow the disconnecting device to be located on the inside of the building under certain conditions. Check your local code for locating disconnecting devices on the interior of buildings or structures.
3. The service disconnecting means shall have a rating not less than the load to be carried.

General

1. All cable, equipment, and devices must be securely attached to the supporting structure.
2. All equipment and devices installed outside and exposed to the elements shall be of the approved weatherproof type.
3. The height of the meter shall not be less than 5 feet nor more than 6 feet from center to finished grade under normal circumstances. In flood prone areas, the meter base and disconnect should be located above the 100-year high water level.
4. All holes in the meter base and switch box must be plugged up with knock out plates or other appropriate devices.
5. Branch circuits may not be supplied from the meter sockets.

Service Entrance

Permanent Overhead Service

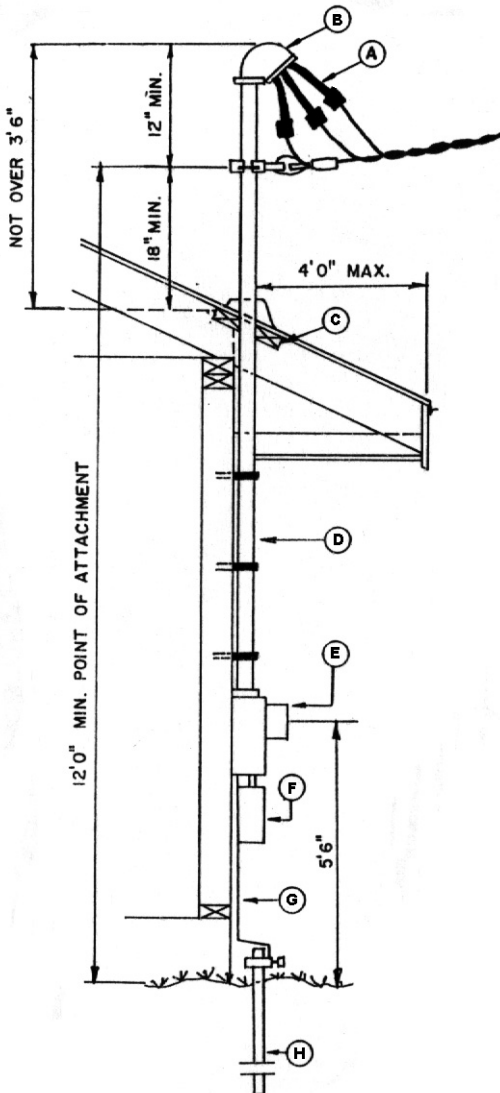

A Service entrance conductors sized according to load and code requirements. Service entrance tail should extend at least 18" beyond the weather-head.

B Rain tight weather-head

C 2" x 4" blocking between rafters. Must be solidly installed.

D 2" inside diameter rigid galvanized conduit minimum.

E Meter base

F Weatherproof breaker panel sized according to load and code requirements.

G No. 4 copper ground wire.

H 8-foot ground rod or approved grounding electrode with approved ground clamp as required by the National Electric Code (5/8" solid ground rod or 3/4" galvanized pipe)

Service Entrance

Temporary Overhead Service

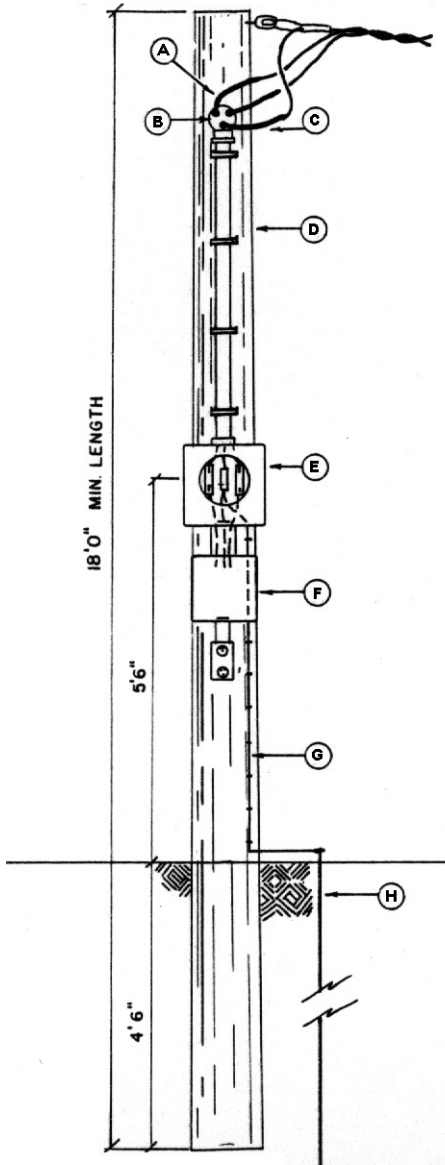

A Service entrance conductors sized according to load and code requirements. Service entrance tail should extend at least 18" beyond the weather-head.

B Rain tight weather-head located within 18" from top of pole.

C Schedule 80 PVC or SE Cable on a meter pole.

D 18-foot minimum length pressure treated pole (creosote, Penta or CCA). Top circumference minimum requirement is 19 inches. A 6" x 6" treated timber is acceptable.

E Meter base.

F Weatherproof breaker panel and receptacles sized according to load and code requirements. All 125 volt receptacles must be ground fault protected and installed in a weather proof receptacle box and cover.

G No. 4 copper ground wire.

H 8-foot ground rod or approved grounding electrode with approved ground clamp as required by the National Electric Code (5/8" solid ground rod or 3/4" galvanized pipe).

Service Entrance

Permanent Underground Service

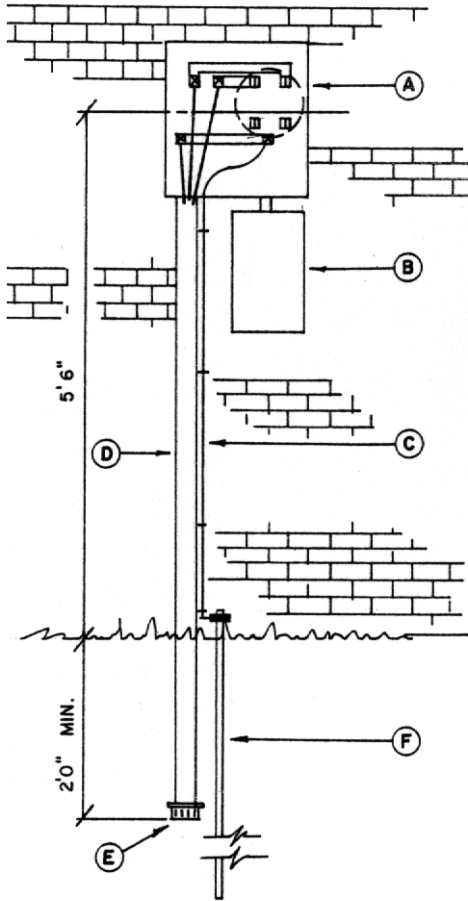

- A** Underground 200-amp meter base.
- B** Weatherproof breaker panel sized according to load and code requirements.
- C** No. 4 copper ground wire.
- D** Riserpipe should be a minimum of 2" inside diameter for a 200-amp service, schedule 80 PVC or rigid conduit. In the event a deck, porch, patio, or pool prevents access to the riser pipe, the riser pipe must be extended out to an accessible location. A long radius 90 degrees and schedule 40 PVC conduit should be installed at a depth of 36" below final grade beyond all obstacles.
- E** Plastic or metal bushing on end of riser pipe.
- F** 8-foot ground rod or approved grounding electrode with approved ground clamp as required by the National Electric Code (5/8" solid ground rod or 3/4" galvanized pipe.)

Service Entrance

Temporary Underground Service

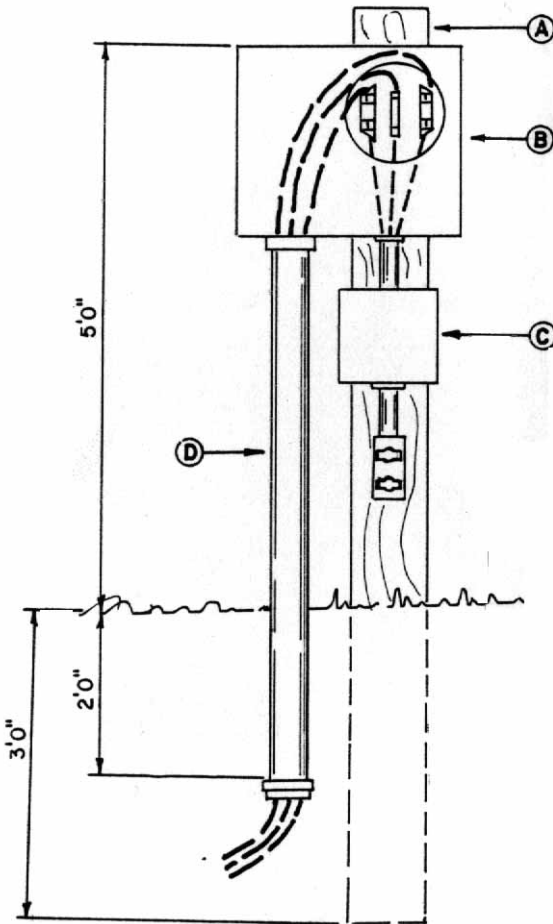

A 8-foot minimum length pressure treated pole (creosote, Penta or CCA). A 4" x 4" treated timber is acceptable. Rain tight weather-head

B Underground meter base.

C Weatherproof breaker and panel and receptacles sized according to load. All 125 volt receptacles must be protected by a ground fault breaker (GFI).

D 1" schedule 80 PVC or rigid conduit extending 2' below grade.

Notes: Service entrance conductors sized according to load and code requirements. The service entrance should extend 10' beyond the end of the conduit for makeup purposes.

No ground rod is required for underground construction pole. A ground rod would be required for all permanent installations.

Place underground construction pole at site. SRE will install and make all necessary electrical connections.



Singing River Electric's Comfort Advantage standards were researched and compiled to create an energy-efficient building program that ensures your family, employees or customers the comfort they deserve.



Standards

1. **ENERGY REQUIREMENTS** - All energy requirements must be served by Singing River Electric through one meter.
2. **ELECTRIC HEAT PUMP(S)** - All heating and cooling requirements must be supplied by an electric heat pump(s) with matched indoor and outdoor units as rated by the Air Conditioning and Refrigeration Institute. Heat Pump(s) should be sized according to a Manual "J" load calculation. SEER rating must meet Comfort Advantage Standards.
3. **ELECTRIC WATER HEATER(S)** - Water heater(s) is to be supplied electrically. Heat recovery device is recommended. Storage tank and hot water supply pipe must be properly insulated. Minimum 90 ASHRAE efficiency rating required.
4. **ATTIC INSULATION** - Attic (ceiling) insulation must have a minimum resistance value of R-30. (R-19 will be allowed for "true" roof-ceiling combinations.)
5. **WALL INSULATION** - The R-value of insulation materials for exterior walls, exposed partitions and attic walls must be R-15 or greater, not including the R-value of other wall components. (The minimum allowable insulation in the wall cavity is R-13.)
6. **FLOOR INSULATION** - Floors over unconditioned areas must be insulated to a minimum resistance value of R-19.

7. WINDOWS – Windows must be double pane or have tightly fitting storm sashes. Total window area must not exceed 20% of the floor area
8. DOORS – Doors between conditioned and non-conditioned spaces should be metal insulated foam core type. Solid wood may be used.
9. ATTIC VENTILATION - Attic ventilation must be adequate for entire area. A combination of continuous ridge and continuous soffit is recommended for most roof configurations.
10. AIR INFILTRATION CONTROL - The following infiltration controls are required: sealed openings on out-side surfaces of exterior walls (wiring and plumbing penetrations); caulked and sealed shim spaces around exterior doors and windows; weather-stripped doors; sealed sole plate; and tightly fitting fireplace dampers. Outside air sources are recommended for all fireplaces.
11. DUCT SYSTEMS – A properly designed, installed and sealed duct system is required. Limited runs of flex duct are allowed. Mastic sealing is highly recommended.

Recommendations

1. Contact Singing River Electric for a plan evaluation and recommendations before you begin construction.
2. Call for a wall insulation inspection prior to installing sheetrock or an interior finish.
3. Contact the marketing department for a final inspection when the home is complete and the permanent meter has been set.

Office Locations



George County (Headquarters office)

11187 Old Highway 63, South
P.O. Box 767, Lucedale, MS 39452
601-947-4211
Office Hours: (Mon.-Fri.) 8:00 am -5:00 pm

Jackson County

500 Highway 90
228-497-1313
228-392-0041
Office Hours: (Mon.-Fri.) 8:30 am -5:00 pm

Greene County

39276 Highway 63, North
601-989-2345
Office Hours: (Mon.- Fri.) 8:00 am -5:00 pm

Additional phone numbers

Perry County - 601-788-2824
Wayne County - 601-735-3139
McLain - 601-753-2198